

48⁹⁹ ID DROP MANHOLE

MANHOLE DESIGN SPECIFICATIONS
 CONFORMS TO: PRECAST REINFORCED
 CONCRETE MANHOLE SECTIONS
 A.S.T.M. DESIGNATION C478.
 LATEST REVISION

DESIGNED TO MEET RESILIENT
 CONNECTORS REQUIREMENTS OF
 A.S.T.M. C-923-79

A LOK GASKET PER A.S.T.M. RUBBER
 GASKET SPECS. C413, CAST INTEGRALLY
 IN MANHOLE WALL AND LOCATED AS
 REQUIRED. JOINT ALLOWS 10°
 OMNIDIRECTIONAL DEFLECTION.

M.A. INDUSTRIES, INC MODEL
 PS-1-PF MANHOLE STEP

CONCRETE COMPRESSIVE
 STRENGTH 4000 P.S.I.

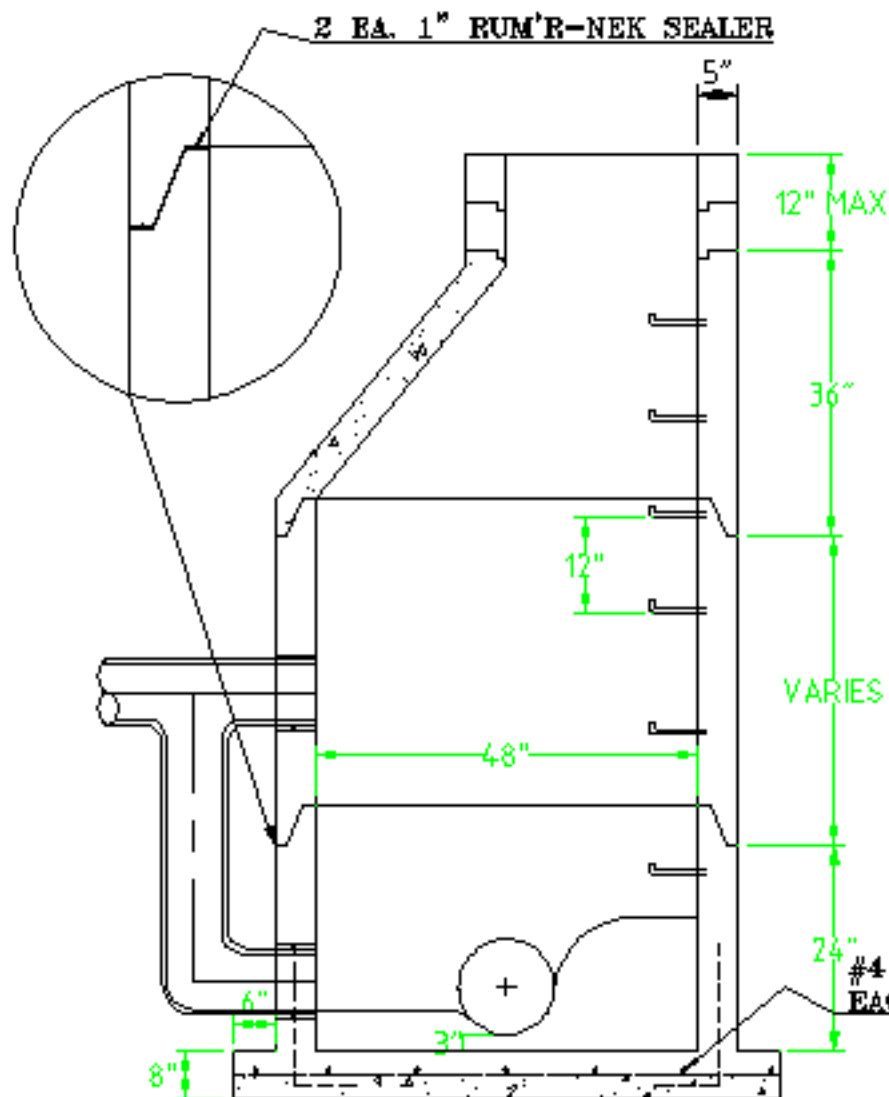

	HANNIBAL CONCRETE PRODUCTS CO 500 RED DEVIL ROAD HANNIBAL MO 63401	REVISIONS	
		BY	DATE
MADE BY MURL SMITH	573-221-4845	ORDER # 48"MANHOLE-E	