

FLAT TOP

MANHOLE

MANHOLE DESIGN SPECIFICATIONS
CONFORMS TO: PRECAST REINFORCED
CONCRETE MANHOLE SECTIONS
A.S.T.M. DESIGNATION C478.
LATEST REVISION

DESIGNED TO MEET RESILIENT
CONNECTORS REQUIREMENTS OF
A.S.T.M. C-923-79

A LOK GASKET PER A.S.T.M. RUBBER
GASKET SPECS. C413, CAST INTEGRALLY
IN MANHOLE WALL AND LOCATED AS
REQUIRED. JOINT ALLOWS 10°
OMNIDIRECTIONAL DEFLECTION.

M.A. INDUSTRIES, INC MODEL
PS-1-PF MANHOLE STEP

CONCRETE COMPRESSIVE
STRENGTH 4000 P.S.I.

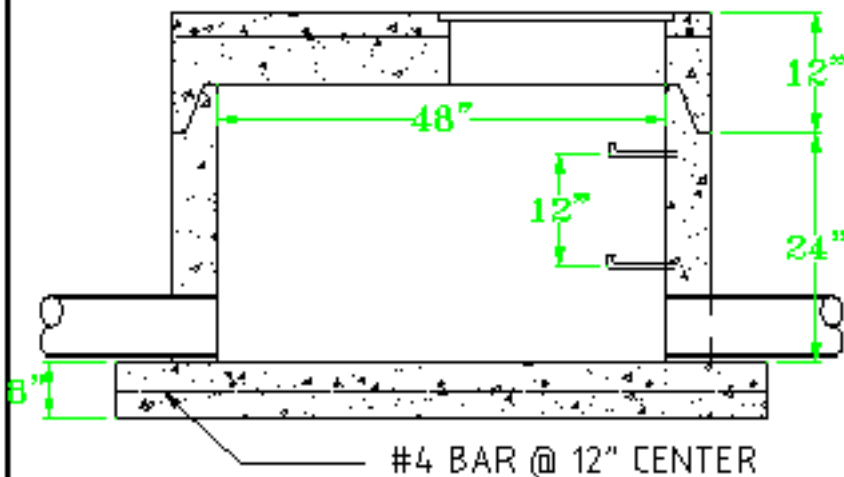
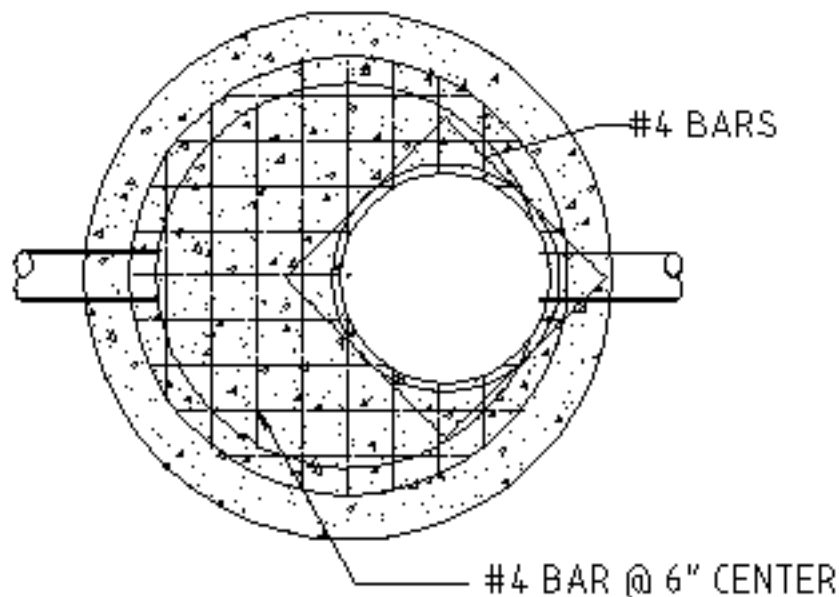

HCP

HAMBAL CONCRETE PRODUCTS CO
549 RED DEVIL ROAD
HAMBAL MO 63491

REVISIONS

BY DATE

WRL SMITH

573-221-4845

FLAT TOP MANHOLE-E